

U
15
U632
no. 20
c. 2

UNCLASSIFIED

U. S. Army Military History Institute

~~RESTRICTED~~

47
**German Methods
of Warfare in the
Libyan Desert**

UNCLASSIFIED

REGRADED _____ BY AUTHORITY

OF E.O. 10501

BY RAKERS ON 2 MAR 87

MILITARY INTELLIGENCE SERVICE

INFORMATION BULLETIN NO. 20

DEPARTMENT • WASHINGTON, D. C.

UNCLASSIFIED PROPERTY OF US ARMY

Distribution

Nondivisional units are being supplied with copies on a basis similar to the approved distribution for divisional commands, as follows:

INF DIV		CAV DIV		ARMD DIV
Div Hq.....	8	Div Hq.....	4	Div Hq.....
Ren Troop.....	1	Ord Co.....	1	Ren Bn.....
Sig Co.....	1	Sig Troop.....	1	Engr Bn.....
Engr Bn.....	1	Ren Sq.....	1	Med Bn.....
Med Bn.....	1	Engr Sq.....	1	Maint Bn.....
QM Bn.....	1	Med Sq.....	1	Supply Bn.....
Hq Inf Regt, 1 ea.....	3	QM Sq.....	1	Div Train Hq.....
Inf Bn, 1 ea.....	9	Hq Cav Brig, 2 ea.....	4	Armd Regt, 4 ea.....
Hq Div Arty.....	1	Cav Regt, 4 ea.....	16	FA Bn, 1 ea.....
FA Bn, 1 ea.....	4	Hq Div Arty.....	1	Inf Regt.....
	-----	FA Bn, 1 ea.....	3	
	30		-----	
			34	

Distribution to air units is being made by the A-2 of Army Air Forces.

THE
DYER INSTITUTE
OF
INTERDISCIPLINARY
STUDIES
BOX 193, ROUTE 1, NEW HOPE
LEHIGH COUNTY PENNSYLVANIA

UNCLASSIFIED



MILITARY INTELLIGENCE
SERVICE
WAR DEPARTMENT
Washington, July 9, 1942

INFORMATION
BULLETIN
No. 20
MID 461

NOTICE

1. This bulletin has been prepared from first-hand reports on German methods of warfare as encountered in Libya; many of the documents are British in origin, but some of the more important are verbatim reprints of captured German orders. The bulletin will serve a dual purpose: (1) To provide all officers with reasonably confirmed information, and (2) to serve as material for lectures to troops. Many of the details can particularly be stressed while troops are in training to deal with enemy tanks. However, the application of this information must be in accordance with the tactics, technique, and procedure prescribed in the pertinent manuals of the U. S. Army.

2. Each command should circulate available copies among its officers. Reproduction within the military service is permitted provided (1) the source is stated, (2) the classification is not changed, and (3) the information is safeguarded. Attention is invited to paragraph 10a, AR 380-5, which is quoted in part as follows: "A document * * * will be classified and * * * marked *restricted* when information contained therein is for official use only, or when its disclosure should be * * * denied the general public."

3. Suggestions for future bulletins are invited. Any correspondence relating to Information Bulletins may be addressed directly to the Dissemination Branch, Military Intelligence Service, War Department, Washington, D. C.

III



UNCLASSIFIED

Section I. GERMAN METHODS¹

In all operations enemy methods must be carefully studied and considered. The following paragraphs contain a description of the way in which the enemy is likely to operate if he has a free hand. They are the result of recent experience and must be studied objectively to discover how we may best take advantage of the enemy's methods in order to enhance the offensive powers of our own troops and to profit by his mistakes. A close study will also disclose many opportunities for local offensive action on our part even when the initiative has temporarily passed to the enemy.

Whether acting on the defensive or the offensive, the enemy covers his front with a protective screen of armored car patrols supported by the other elements of his reconnaissance units, which include a motorcycle company, antitank troops, and a few infantry guns. In each of his armored car companies he has a proportion of 8-wheeled armored cars which he uses to support his lighter armored cars. Occasionally he employs a few tanks in support of his reconnaissance elements, and in some reconnaissances light tanks entirely supplant armored cars. These reconnaissance detachments are very active and highly trained. The information which they pass back is usually accurate, and they report not only our movements but those of

¹ This section is taken from a British pamphlet on tactical doctrine. It reveals the German methods which have been experienced by the British in Libya.

their own units. Skill and determination, knowledge of the terrain and changing road conditions, along with the ability to deal effectively with small mixed columns, including tanks, are necessary both to pierce this screen and to prevent enemy reconnaissance detachments from penetrating our own protective screen.

When the enemy has decided to attack, he first makes a very thorough reconnaissance, probing the position from all directions to test its strength, and endeavors to induce the defenders to disclose their dispositions by opening fire. During this period his observation posts keep close watch and note the location of guns or antitank guns which disclose their position so that these may be dealt with when the main attack begins.

Having decided where to strike, the enemy next brings forward his tanks supported by some motorized infantry. He covers this move by a screen of antitank guns, and endeavors to bring his forward elements to within some 2,000 yards of his objective. At this stage he may be expected to refuel his tanks under the cover of his forward detachments.

Choosing a time when the position of the sun will most favor his attack, the enemy then proceeds to carry out his final preparations. He first engages our antitank guns and artillery with his Mark IV ² tanks and supporting

² The German Mark IV is a medium tank of 22 tons, carrying a crew of five. Armed with one 75-mm. gun and two light machine guns, it has been used primarily as mobile close-support artillery in desert warfare, although the reported substitution of a more powerful 75-mm. gun may return the tank to its normal role; the maximum speed is 31 m. p. h. It has eight small bogie wheels and four return rollers. See War Department TM 30-450, *Handbook on German Military Forces*, December 17, 1941, pp. 165-166, for pictures of this tank.

guns; meanwhile, Mark III ³ tanks form up for the assault and frequently challenge the defended area at different points in strong compact formations. Then, having decided where to launch his main thrust and having endeavored to reduce the power of the defense by the fire of his Mark IV tanks and artillery, he launches a strong attack with his Mark III tanks followed by motorized infantry and guns direct on his objective. In addition, the enemy often directs at least one column containing tanks, artillery, and motorized infantry on some important locality in our area, such as the field maintenance center. There may be one or more of these thrusts. As a rule, the Germans try to develop a pincer movement, the two lines of advance converging on the final objective. An attacking column will move fast and straight to its objective irrespective of events elsewhere.

If one of the enemy's tank columns succeeds in penetrating and overrunning any part of the defenses, motorized infantry, carried forward to within a few hundred yards of the objective, rapidly endeavor to mop up and consolidate the position. The infantry is closely followed by machine guns and antitank guns, and every effort is made to turn the captured position as quickly as possible into a defense area or series of defense areas, with all-around defense against any form of attack. As the enemy often launches his attacks in the late afternoon in order

³ The German Mark III is a light medium tank of 18 to 20 tons. Originally it was armed with one 37-mm. gun and two light machine guns, but in most cases the 37-mm. has been replaced by a 50-mm. Its maximum speed is 28 m. p. h., but it is more maneuverable than the heavier Mark IV. For pictures of this tank, see WD TM 30-450, *Handbook of German Military Forces*, pp. 164-166.

to have the advantage of the sun at his back, the light will generally have begun to fail by the time the action is completed. The best opportunity for a counterattack is undoubtedly as soon as darkness has fallen. Experience has shown that the German particularly dislikes this form of attack, and counterattacks launched at night have almost invariably succeeded at little cost in recovering ground lost during the day.

If, by his attacks, the enemy forces us to carry out a general withdrawal, he will follow up, as a rule, with the whole of his armored forces as long as his administrative resources permit. When he becomes separated from his supply elements, he will probably attempt to continue the advance with battle groups that are really mixed columns and usually include some tanks. These columns are boldly and skillfully handled and always aim at outflanking our rearguards. During the German advance in the Western Desert in January 1942, these battle groups were concentrated on one axis. Such action is typical of German tactics, concentration of effort being a principle the German rarely, if ever, fails to follow. Speed is another characteristic of the action of his armored forces.

In defense, the enemy chooses the most suitable ground for combined action by infantry, machine guns, antitank guns, artillery, and tanks. He usually constructs a series of defense areas capable of all-around defense against any form of attack. These areas are in such depth as his resources permit. His tanks will be found echeloned in depth on the most dangerous flank, or located so as to protect weak points in his defensive system. His artillery will be placed where it can support either his defense areas

or his tanks if they are launched in a counterattack. On more than one occasion, he has disposed his tanks in two separate groups and has used the two groups to execute a pincer movement against our attacking troops. When used in such a counterattack, his tank columns are accompanied by artillery, machine guns, and motorized infantry, and they operate on the same general lines as in the attack. The garrisons of his defense areas fight stubbornly and cannot as a rule be maneuvered out of position.

When the enemy has decided to withdraw, first of all he thins out his transport. He does this skillfully, and the operation is often hard to detect. As often as not, his tanks then move forward, either to form a protective screen, to carry out a demonstration of considerable force, or to launch a definite counterattack to cover the withdrawal of the remainder of his force. This often takes place in the evening, and during the night the whole force withdraws, leaving only reconnaissance elements supported by a few guns to hold up our patrols in the morning. These enemy patrols are normally provided by the reconnaissance units, who then resume their role of forming a protective screen.

The German does not fight a delaying action with his main forces. He will form small battle groups, which correspond to our mobile columns, to support his reconnaissance units and to act as rear guards, but his main forces—which, in case of withdrawal, will probably include all his tanks—will break off the engagement completely and move quickly to the next area in which he has decided to offer serious resistance.

In any type of operation, the enemy can be expected to employ wide-ranging raiding parties consisting of detachments of motorized infantry with a few guns. These raiding parties endeavor to operate against our landing grounds, headquarters, and communications. Unless adequate protection is provided against them, they can cause serious dislocation. They are particularly menacing to advanced landing grounds and transport columns.

The above notes have been based on recent experience with German operations in the Western Desert. Knowledge of them will often give a definite indication of what the various activities on the enemy's part foreshadow. It must not, however, be assumed that the enemy will always pursue precisely the same tactics. He is adept at ruses, and, though stereotyped in some respects, he has shown that he can adapt his tactics to changing situations. The most obvious recent example of this is his new technique for using Mark IV tanks to neutralize our artillery and antitank guns before an attack, which he adopted as soon as he appreciated the power of our 25-pounders (3.45-inch gun-howitzers) in an antitank role.

This review of the enemy's methods shows only too clearly the close attention he pays to adequate preparation, concentration of effort, speed of action, and close cooperation between all arms. To defeat him, we must do the same.

Section II. GERMAN TANK TACTICS

1. REPORT BY A BRITISH OFFICER¹

“On the withdrawal of our tanks (British), German Mark IV tanks advanced and came hull down on our 25-pounders, which they engaged. The Mark III's hung back behind the Mark IV's and advanced on our guns under cover of the fire of the Mark IV's.

“Fire orders and orders to the gunners appeared to be given by voice and not through I. C. (intelligence control) system. The commander of the unit was in a Mark II tank. He kept 60 to 80 yards behind the line, cruising backwards and forwards, and his radio control appeared to work very well. There was another Mark II apparently carrying a F. O. O. C. (Forward Observation Officer Command). The tanks were supported by 88-mm. (3.4644-inch) dual-purpose guns towed by tractors;² they kept close behind the tanks and advanced with them by bounds. No observation-post truck was visible, so that it was certain that the observation post must have been on a tank. When the tanks withdrew, the guns

¹ Quoted from the report of a wounded British tank officer whose statement is based on his personal observation.

² Although the 88-mm. (3.46-inch) gun is basically a dual-purpose weapon, as mounted on its model 201 trailer and towed by a tractor, it has an elevation of only -3° to $+15^{\circ}$. Consequently it is limited to ground targets unless removed from its mount.

remained and gave them covering fire until all had gone; they then withdrew themselves and were very quick in coming out of action."

2. COMMENTS OF THE U. S. OBSERVER

The German armored force unit has a high proportion of very effective antitank and antiaircraft artillery. German tactics involve close coordination of tanks and artillery, with the artillery serving as antitank guns. The artillery is placed well forward and is advanced from its initial positions by bounds with the forward movement of the tank force. Withdrawal from action is customarily covered by artillery or antitank guns which themselves withdraw after the tanks have cleared. British armored units have suffered heavily on many occasions when they have been thus lured into the range of Axis artillery.

When a high-ranking British officer was asked why the R. A. F. had not more frequently attacked definitely-located concentrations of miscellaneous transport, undoubtedly supply vehicles of German armored units, he stated that the high proportion of antiaircraft artillery which was customarily placed in protection of such concentrations made low-elevation attacks too costly and that the difficulty in clearly determining the identity of the concentration made high-elevation air attacks too dangerous to the British ground forces.

The German armored force, even the smaller units when operating alone, is a well-balanced, self-contained fighting unit. Its tank weapons and its antitank and antiaircraft weapons have been designed to outrange the weapons of their opponents.

3. REPORT BY AN ESCAPED BRITISH OFFICER ³

“At about 1000 January 21, 1942, I was captured by two German armored cars. Their advance was going pretty well just then; so they had no time to take us back. Later, we were taken to HQ, where we were asked a few questions and searched. I was then put in a saloon (sedan) car in which we followed the battle all day at a distance varying from 200 yards to 1½ miles behind the tanks.

“The German force consisted of about 35 tanks, half of which were Mark IV's; 8 field guns rather larger than our own 25-pounders; 4 medium guns; at least 4 antitank guns; 4 antiaircraft guns; 1 eight-wheeled armored car; 2 light armored cars; and 1 A. F. V. (armored fighting vehicle). Immediately behind came about 10 trucks—all containing fitters (mechanics)—in one of which I traveled.

“The tanks were divided into two groups which advanced together or one at a time, depending on the opposition they encountered. They advanced by bounds and usually halted in horseshoe formation. When they advanced, two guns were advanced with each group, leaving two in action. When they came up against opposition, the guns with the tanks dropped into action beside them. When the advance continued, the rear two guns leap-frogged.

“There was considerable German air activity and the cooperation between ground and air was close. Messages were dropped on three occasions which I saw, and there must have been others. The ground-to-air recognition signal is a magenta-colored (purplish red) smoke

³ This is a report based on experiences as a prisoner of war in Libya.

cartridge fired from a special smoke projector. The Germans also draped red swastika banners over some of the vehicles. The medium guns followed us about 1½ to 3 miles behind. I never saw them in action. No precautions were taken against air attacks, vehicles constantly being closely bunched.

“The advance halted about 1730, and at about 1815 we went into night leaguer (bivouac). The tanks formed a vast circle facing outwards, with everything else in the middle. They did not close right up as do our close leaguers, but every vehicle was about 50 to 75 yards from the rest. Patrols were circling the leaguer all night, and white Very lights were sent up every few minutes. Next morning they stayed where they were, not opening out at all. ‘B’ Echelon⁴ came up on a long crocodile, nose to trail, and the tanks were refueled. The petrol (gasoline) was all brought up in 50-gallon drums and was decanted from these into the ordinary 5-gallon cans. This was considerably slower than our method of distribution, but there appeared to be no waste.

“After refueling, the tanks moved off in a northwesterly direction, followed by ‘B’ Echelon. I was placed in a Dodge 8-cwt. anti-aircraft truck, following ‘B’ Echelon. While they were towing out a bogged three-tonner, the four men in the truck were all on the ground together; so I got into the driver’s seat and dashed off flat out through the rest of ‘B’ Echelon and escaped.

“The German morale appeared to be very high, in spite of the fact that the Germans had been retreating steadily since Salum. They had no doubt that they

⁴ Supply trains.

would finish off the war in Africa very quickly, and the whole war quite soon. Their propaganda has been very successful, and they said that we had lost 400 tanks at Tobruk. The food was very good and much more varied than we got.

“There were about two Italian tanks from the Ariete Division which came into the leaguer. One of the Italians came up and talked to the Germans in my truck and also to me. They seemed certain that the Ariete Division would get through very quickly to Alexandria and Cairo. The Germans regard the Italians as rather a joke and are very contemptuous about their fighting qualities.

“They had a large number of British vehicles in use with their forces. Nearly half their ‘B’ Echelon was British, and they also had a lot of 8-cwts. Their own gun tractors are very efficient, having two wheels in front and tracked bogies behind. I saw one towing a gun through soft sand, and behind the gun a 3-ton truck.”

Section III. ORGANIZATION OF A GERMAN DEFENSIVE POSITION

1. "BASIC CONSIDERATIONS

“The Division will defend its allotted sector; that is, each man will hold his own position to the last round against any attack, ignoring the behavior of his neighbors and any orders to the contrary. Our positions are so strong that they are impregnable if every defender does his duty.

“As the front here is not solid, all subsectors (and in these, all defense areas, and, as a last resort, all firing positions) will arrange for all-around defense and an all-around field of fire.

“If the enemy breaks into the ground between subsectors or surrounds these latter, subsectors will defend themselves to the last. If the enemy penetrates the subsectors, each defense area and each firing-position will be defended, and the enemy penetration broken up by the concentric fire of all arms or by a bold-fronted bayonet charge.

“The whole point of this battle on the Salum front is to destroy the enemy, or, failing this, to inflict maximum

¹ This extract is from a document recently captured at Salum. It is in the form of orders for the German 90th Light Division at Salum.

losses on him and delay him until the Tank Corps finds a favorable opportunity to destroy him completely.

“As the struggle will be principally against the enemy’s tanks, the defense must be built around the antitank defense. This will have priority over everything else; all the best positions will be allotted to it. Moreover, antitank defense means not only the defensive positions of the antitank weapons (antiaircraft and antitank guns and rifles) but the position of any weapon that has any chance of taking part successfully in antitank defense. The enemy’s tanks are the most important target of all arms. Weapons not employed in an antitank role will take over the defense of the weapons engaged in an antitank task.

2. “COURSE OF THE FIGHTING

“In the face of attack by hostile tanks the battle will be split up roughly into the following stages (although these will obviously interlace):

a. “1st Stage

“Antiaircraft and antitank guns open up on the attacking tanks at the most profitable ranges. The main weight of fire will be reserved for tank concentrations and for armored fighting vehicles attacking through gaps in the mine fields.

“The artillery will take as its principal target any enemy artillery accompanying the tanks, especially the guns which are firing. If there is no enemy artillery, our own will join the concentrations on the massed tanks.

“The infantry will open up with machine-gun and

rifle fire on enemy aircraft giving low-level support to the attack. At this stage this is not the task of the anti-aircraft guns.

b. "2d Stage

"Antiaircraft and antitank guns and (as the enemy comes nearer) static guns (temporarily or permanently immovable) and antitank rifles begin to engage the enemy tanks. The nearest tanks will now be engaged; the guns may have to reckon on firing over the heads of the infantry.

"The artillery continues engaging enemy artillery accompanying their tanks or the motorized infantry following them. In the absence of such targets they will fire concentrations on tanks massing in back areas.

"The infantry continues antiaircraft fire and also fires at the slits of the nearest tanks.

c. "3d Stage

"The real antitank weapons continue engaging the enemy's tanks, especially any that have broken into our positions. Our own comrades may even be in some danger from this antitank fire, but it will certainly be less than the danger from hostile tanks. All-around observation is a vital necessity.

"The artillery continues as before.

"The infantry will, at this stage, be relieved of its antitank task by our own aircraft. The infantry will destroy odd tanks which have broken into our own positions by means of assault parties armed with petrol bottles, pole-charges (explosives on poles—used to thrust

into tanks), etc., and use its own weapons against enemy infantry following the tanks.

“If the enemy succeeds in any measure in penetrating the subsectors, he will be destroyed as soon as possible by encircling assault groups.

“If the enemy tanks break into the ground between subsectors, the real antitank defense will take them on. The artillery and the infantry will continue to fire to the front, singling out the unarmored attackers.

“Immediately the attack has been broken off, the defense will be reorganized.

3. “GENERAL

“These directives will be thoroughly studied by all commanders. The men will be regularly instructed in this sense by company commanders and so schooled in the ground around their positions that, in an emergency, every man will act of himself in the way he believes the higher commanders would have ordered.”

4. COMMENT

Of interest is the directive to the infantry to concentrate their fire against aircraft in the first stages of the attack, leaving the anti-aircraft guns free to deal with the tanks, and the use of aircraft in the defense.

Section IV. LESSONS FROM LIBYA ¹

The first part of a captured German document deals with motor vehicles. The following is a summary:

Motor cars have proved unsatisfactory in the desert. The light cross-country car (*Volkswagen*) can get through any terrain except shifting sand dunes. Medium and heavy cross-country cars can cross any type of country. Trucks (Opel Blitz "S" and Ford V8) do not stand up well on long desert drives, but show few complete breakdowns. Twin wheels have been found to be unsatisfactory, as stones get jammed between them. Armored cars are satisfactory. Panzer Kraftwagen I ² is considered too weak and slow, breaking down frequently. Panzer Kraftwagen II is useful when employed as a reconnaissance vehicle or as a command car. Panzer Kraftwagen III was found to be satisfactory after the new broad tracks were introduced. Panzer Kraftwagen IV is entirely satisfactory. Likewise, the half-track carriers and the armored carriers for motorized infantry have proved to be satisfactory.

The only vehicle which has mastered all types of cross-country going is the half-track carrier. It can surmount

¹ Taken from a captured German document issued by the School of Armored Troops at Wuensdorf, dated October 16, 1941, on Lessons from the African Theater of War.

² For characteristics of German armored vehicles, see War Department TM 30-450, *Handbook on German Military Forces*, par. 99.

dunes of shifting sand with a 40 percent gradient, without difficulty or help.

Tanks, also, have mastered any country that has been met in desert warfare, except dunes of shifting sand, and can cross even these if of low gradient. Vehicles with all-wheel drive can cover all types of ground encountered to date—for example: Sand, loose stones, stretches of flat desert—provided that there is no gradient over 25 percent and the sand is fairly firm. Shifting sand dunes can generally be circumvented. The assistance of British perforated sand-channels proved very useful for vehicles stuck in soft ground. Vehicles and motor cars with rear-wheel drive are confined to tracks—if these are badly cut up, other ways must be found. Stretches of country which are impassable for the usual tropical vehicles are rare.

Fuel consumption on roads is no higher than in Europe. On desert marches it is 50 percent higher for wheeled vehicles, and 30 percent higher for full or half-track vehicles. Oil should be changed more frequently than in Europe—at least every 1,000 km. (625 miles).

The following three sections are of special interest and are reproduced in full:

1. "ARMS AND AMMUNITION

"All arms have proved satisfactory to date, and it has also been ascertained that with proper care and belt-feeding, no serious stoppages occur on machine gun No. 34.³ Owing to the dust and dirt, arms must always be kept dry and polished.

³ Dual purpose; caliber 7.9-mm.; maximum rate of fire: on bipod, 110 to 120 rounds per minute; on tripod, 300 to 350 rounds per minute. For other characteristics, see War Department TM 30-450, *Handbook on German Military Forces*, par. 77.

“The 50-mm. (2-inch) armor-piercing high-explosive and nose-fuze shells (*Kopfgranaten*) go straight through all enemy tanks up to a range of 300 m. (330 yards). Mark IV and Mark VI can be dealt with by the 50-mm. tank gun at all ranges.

“Ammunition consumption in tank encounters is high. The reasons for this are: The good visibility and the resulting opportunity for pursuit; opening fire too early; and shooting at retreating tanks when they are out of effective range.

“Owing to the extensive use made by the British of Infantry Tank, Mark II (over 100 in the Battle of Salum on June 15 to 17, 1941), the weapons which can be relied on to pierce this tank come into the foreground. In the first line should be an 88-mm. (3.46-inch) antiaircraft gun and a 50-mm. (2-inch) antitank gun No. 38, also a 20-mm. (0.79-inch) antitank gun No. 41. These form the skeleton of the defense; the 88-mm. antiaircraft gun is also used in every offensive operation. Teller mines are extensively used.”

2. “SPECIAL FEATURES OF BRITISH TACTICS

“The following tanks have been used by the British to date:

“Infantry tank, Mark II; cruiser tanks, Mark IV and Mark VI. There has been much emphasis in reports on the good cooperation between British tanks and artillery (85-mm. (3.40-inch) and 105-mm. (4.20-inch)) which is very mobile as close-support artillery.

“Artillery fire is usually very accurate and is often directed by three armored cars. Fire is accurate even against moving columns, and when it is opened, the

troops are much worried. In general no serious effect was produced on the tanks, except for the discomfort caused by the closing of the slits.

“The effect of fire by the tanks themselves was not usually great, as the British fire chiefly on the move.

“An effective opposition to British tanks is produced by the quick formation of a fire front or by approaching to effective range. The lack of coordination and determined leadership is felt. All English tanks can be effectively engaged within the range of our guns (50-mm. (2-inch) tank guns), in which connection it is noteworthy that the infantry tank is easily set on fire and the cruiser tank, Mark VI, is very thinly armored. On the other hand, the cruiser tank, Mark VI, can be pursued with difficulty, since this vehicle (Christie type) has an extraordinary high speed of 50 to 60 km. (30 to 37 m. p. h.). To engage these tanks effectively at longer range, the employment of sufficient 88-mm. guns is needed; these guns can also knock out the infantry tank at long range.

“Targets on British tanks are: The skirting, which buckles easily (protective covering); the stern; the driving sprocket; the tracks; and the lower corners of the turret.

“Beware of British trucks, for the British mount ATk (antitank) guns on them with which they open fire unexpectedly over the stern or the engine. The British carry out dashing (reconnaissance) patrols by means of wheeled AFV's (armored fighting vehicles) and on foot. They also appear from the desert to make thrusts deep into our rear lines, launching shock troops or attacking our rear columns with fast-wheeled armored fighting vehicles.

“The laying of mines at defiles (passes and gaps in wire) must be expected. In doing this, British patrols use

small rubber-tired hand-carts and rubber-soled shoes. Mines are also dropped by aircraft in the shape of thermos-flasks and boxes painted to look like tinned food with German markings.

“British air attacks should be met with fire from all light arms. The English are particularly sensitive to the 20-mm. (0.79-inch) gun.”

3. "TACTICAL NOTES

“In the desert, close reconnaissance must be pushed far ahead.

“Targets can be recognized exactly only during the morning and evening. In the middle of the day, the light is so dazzling, because of the heat, that all outlines are completely blurred and distorted—tanks appear like bushes, bushes like tanks, and so on—and much practice is needed.

“In parts of the desert with wadies up to 30 miles long, the flanks of columns marching lengthwise up the valleys must be covered by a platoon or company on the ridge; when crossing the valley, close reconnaissance must always be carried out as far as the next ridge. Panzer Kraftwagen II is too slow for this, and also too weak; use Panzer Kraftwagen III and IV.

“In general, the principles of tank combat have justified themselves entirely and are to be applied unaltered. The North African desert is ideal tank country with unlimited space for maneuvering. Battle formations in large units (regiments or brigades) and tank battles up to a depth of 100 km. (62.5 miles) are possible everywhere. Now that the medium squadron is armed with the 50-mm. (2-inch) gun, it is not necessary to employ it in a forward position; it should be kept immediately under the control

of the battalion commander; and only when the battle, has developed clearly, should they be thrown in at the critical point. In the desert, the broad battle order proved effective (two light squadrons ahead, medium in the rear) in a regiment, and battalions should be disposed one in rear of another. Owing to dust and artillery fire the distance between tanks should be raised to 100 to 150 m. (110 to 165 yards)—hence a gyroscopic compass in each tank. In an attack, enforce alternate fire and movement, since the desert tempts one into attacks on the move. In contrast to the English, we still lack mobile close-support artillery.

“Mark II is the British infantry tank which has a speed of about 25-km. (15 miles) per hour. The armor on the front is 80 mm. (3.15 inches) backed by concrete, and it carries a 40-mm. (1.6-inch) gun. The British generally use these tanks in a close formation of a front of fire, which is most effective when high-speed fire is directed against the skirting of opposing tanks. An equal number of Panzer Kraftwagen III should thrust at full speed, without stopping to fire, at the flank of the enemy tanks until they are within a range of 300 m. (330 yards), and then open fire, using alternately A. P. H. E. (armor-piercing high-explosive) shells and A. P. (armor-piercing) nose-fuze shells. (Infantry tanks are easily set on fire—50-mm. (2-inch) shell pierces clear at 300 m. (330 yards).

“The use of lightly armored vehicles for supplies of ammunition and fuel should be sought, for the range of tank units is cut down perpetually by lack of supplies. In most cases trucks could not get through to the fighting tank units, whereas lightly armored fast vehicles could easily have reached them.”

Section V. LESSONS FROM THE DEFENSIVE ACTION FOUGHT BETWEEN 15TH AND 17TH JUNE, 1941 (SALUM) ¹

"15 Armored Division
No. 580/41 (secret) Ia.

Divisional Battle H.Q.
25 June 1941. (SECRET)

"In spite of our great defensive victory in the Battle of Salum from 15–17 June 1941, we must reckon with the possibility of further British attacks in the near future. It is therefore necessary to learn from the recent actions those lessons which are important, so that when next the enemy attacks, we shall be able to beat him off even more successfully than this time.

"RECONNAISSANCE

"Only in a few cases were omissions made in reporting the location, time, and direction of observed enemy columns. It is particularly important that patrols, including standing patrols, should keep in contact with the enemy and report continually on the latter's further movements.

"DEFENSE AREAS

"The value of the preparation and construction of our defense areas was fully demonstrated. The crews of the

¹ Translation of German document captured in Libya.

light and heavy infantry weapons and of the antitank weapons were protected by their antitank trenches even after enemy tanks had broken into the defense areas, and could continue offering resistance to the enemy with relative immunity to themselves. Such antitank trenches are to be dug at all defense areas.

“Many enemy tanks were put out of action by the spirited use of close-combat weapons. Knowledge of these weapons will shortly be disseminated by a course run by the 33d Engineer Battalion.

“It was further demonstrated that the siting of all antitank weapons must provide for all-around defense so that they can be used to engage tanks which have broken into the defense area.

“The *personality of the officer commanding* is the most important guarantee for the successful defense of the position.

“The strength of our defense areas consisted chiefly in the *surprise* effect obtained from their siting. In particular, the well-camouflaged defense area at Point 208 remained completely hidden from the enemy, even after he had penetrated into its neighborhood. Wherever high stone walls still remain, they must be removed as quickly as possible. They are to be used only in constructing dummy positions. In the construction of present positions camouflage must be taken into consideration from the start in order to keep them hidden from enemy reconnaissance from the air.

“To increase the element of surprise, all antitank weapons should open fire only when they are certain of success. Even after 88-mm. (3.46-inch) antiaircraft guns have

already opened effective fire, the 37-mm. (1.48-inch) and 50-mm. (2-inch) antitank guns must remain silent so as not to be observed by enemy tanks. Only at a distance of a few hundred meters are they to open fire on the heaviest English tanks with the antitank shell No. 40.

“The battle situation on other sectors of the front may necessitate detachments in the defense area being withdrawn and used in a mobile role. *Mobility and adaptability* must therefore be assured throughout the garrison.

“During the battle the 8th Tank Regiment successfully engaged an enemy, greatly superior in numbers. In the course of the action, it cooperated skillfully with other arms and gained valuable experience in the performance of its own weapons against the heaviest enemy tanks. The *general lesson* to be drawn is:

“If a tank regiment is being held in readiness behind a defensive front as a mobile counterattacking force, all preparations must be made to insure a rapid start. Every quarter of an hour saved is of great value.

“To halt when under enemy artillery fire is always wrong. Experience also shows that when on the move, widely dispersed tank units are harder to hit, and also harder to locate in the desert. Their strength is usually overestimated, as the enemy mistakes wheeled vehicles for tanks.

“A sudden dash in one direction has also shown itself to be the best course in the face of artillery fire and against enemy tanks which attack from several directions. In such cases limited objectives are preferable.

“Covering fire is to be provided by the majority of 88-mm. (3.46-inch) antiaircraft guns and artillery; some

of these weapons are to accompany the tanks into action. Tanks can often leave the initial firing to their accompanying antiaircraft artillery. Strict economy must be observed in the use of the antitank shell No. 40.

"ARTILLERY

"The static artillery is an integral part of the defense area. Its task is to prevent the forming-up of tanks and motorized infantry; to scatter enemy columns pushing past the defense areas, and compel them to turn about; to engage enemy infantry attacks against the positions (at night by means of a barrage if necessary); and also to destroy at close range tanks which have penetrated within the defense area.

"Preparations must be made for the rapid removal of the artillery for mobile action outside the defense area should the commander give such an order.

"The commander of the supporting artillery must maintain close touch with the commander of the tank unit. As a rule, he should remain within close proximity to the latter. The supporting artillery, it is to be noted, must always provide protection to the tank unit when called upon, without, however, interfering with the mobility of the tank regiment when such protection is required. Care must therefore be taken that a proportion of the guns are always ready for action, should favorable targets present themselves.

"The tasks of the supporting artillery are as follows:

"The destruction of enemy tank units which are forming up for a tank battle.

“The engagement of enemy artillery and antitank weapons which are threatening the tank unit.

“The annihilation of infantry on mechanized transport; in special cases the engagement of tanks at close range; as a specially important task the engaging of a retreating enemy after a successful tank attack has been made by our own tanks.

“As a general rule, it is not the task of the supporting artillery to engage at very long range enemy tanks which have already deployed.

“MOTORIZED INFANTRY

“Motorized infantry units are usually self-contained. They are to be handled in such a way as to insure sufficient protection against enemy tank attacks from the front or from the flanks. Open formations are preferable so as to keep down losses in the face of enemy attacks.

“The principle that rapid movement, with vehicles well spaced out, is the best protection against enemy artillery fire applies also to motorized infantry units. Only in exceptional circumstances should men get off their vehicles.

“The Divisional Signal Company, with its limited resources, did all it could to facilitate the transmission of orders during the battle. In the future even more care must be taken to see that the higher command can listen in to the radio communications of as many parts of the Division as possible, especially to those of the patrols of the reconnaissance unit. This must be achieved with the minimum number of radio trucks.

(Signed) NEUMANN-SILKON.”

Section VI. GERMAN DESERT GROUND DEFENSES¹

“Characteristic of enemy defenses was his complete reliance placed on concealment from the ground. Trenches were narrow; the parapet was spread out and never more than 9 inches high. The effect was to make the trenches most inconspicuous, and in one case an officer walked to within 30 yards of an enemy post without seeing it. There were no sandbags, few wire obstacles, and a general absence of defense stores; though this may have been by force of circumstances in the first instance, it proved entirely effective in the event, and made his defenses very difficult to locate. Revetting (facing of wall or embankment) was usually dry-stone walling, but very few posts had overhead cover, protection from the air being obtained rather by the narrowness of the trenches than by concealment. In one area a number of ‘I’ (infantry) tank turrets were used as pillboxes in fixed defenses and were very effective, providing good protection and being easy to conceal.

“We must give more consideration to the siting of our wire obstacles; provided that they are under fire (otherwise they are practically useless as obstacles), it is better

¹This is taken from a British report.

to have them 200 yards away and concealed from the enemy, such as on a reverse slope or in a hollow, than to have them constructed to a geometric pattern 50 yards from the post and in the open.

“If time permits, consideration should be given to digging a wide shallow ditch in which to put the barbed wire. But this involves a lot of digging and is possible only in deliberate defenses.

“If it is not possible to conceal the barbed wire obstacle in such a manner, it may well be preferable to obtain concealment by having no (barbed) wire at all. In such cases antipersonnel mines may be substituted, but only if they are available in sufficiently large numbers.”

Section VII. ORGANIZATION OF DEFENSE¹

5th Light Motorized Division—10 July 1941

The following summary of the principles controlling the organization of defense in the African theater of war is taken from orders issued by the German Africa Corps, based upon its experience gained at Tobruk and Sidi Omar.

“The tendency to form a thin, unbroken line for the defense of broad sectors, instead of a series of defense areas organized for mutual support, must be combated.

“The smallest defense areas will be built around a heavy weapon, if possible an antitank weapon, covered by machine gun, rifle, or machine pistol. The positions of the three weapons are to be connected by a crawl trench. Blue prints showing the method of carrying this out will be distributed down to companies.

“Particular care must be taken to incorporate in the plan the tents of the defense area personnel so that the

¹ This is a translation of a German document captured in Libya. In this translation principles governing organization of defensive positions are discussed. The German builds his defense about his basic weapon, usually an 88-mm. dual-purpose gun if possible. He does not fit his weapons into a preconceived defensive layout. To insure readiness for action, living quarters and fighting quarters are combined. Dummy positions are essential and communication trenches are frowned upon. Mining is all-important.

holes cut for the tents can later be included in the connecting trenches. In subsequent stages, the shelters built for the defenders must be made splinterproof. The principle aim must be to combine fighting and living quarters in one position, for only thus can there be constant and immediate readiness for action. All junior commanders must be instructed in person that every position must be laid out according to this principle, whether it is a question of the organization of a planned defensive position or merely a temporary digging in during the course of an attack.

“Several such small-unit defense areas form a platoon defense area. The unit areas must be organized in breadth and depth and checkered so that all intermediate ground is covered by fire.

“The depth of the platoon defense area depends upon the width of front allotted to it. The minimum for a series of checkered section defense areas is a total depth of 100 m. (110 yards). The aim should be, however, to have three lines of checkered defense areas, one behind the other, with a total depth of 200 m. (220 yards).

“The company is organized into three platoon defense areas which either are organized in depth one behind the other without intervening spaces or else lie side by side with intervening spaces (for the defense of a wider front). In the second case, care must be taken that the intervening spaces between platoons are covered by fire or blocked by mine fields.

“If, in exceptional circumstances, the company is employed in isolation to form a defense area capable of all-

around defense, the three platoons will be organized in a triangle, according to the ground, as follows:

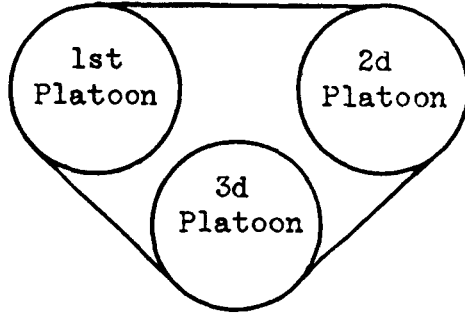

“The gaps between the platoons will be covered by fire or closed by mines according to the size of the company defense area.

“An organization similar to that of the platoons in a company can be applied to the companies in a battalion.

“All attached weapons, 88-mm. dual-purpose guns, artillery, etc., must be included to form pockets of resistance within the battalion defense area.

“Care must be taken in laying out the defense area that the commanders of weapons which operate together will have the necessary close contact with each other. The battle headquarters of the infantry, artillery, and 88-mm. dual-purpose gun commanders should be placed close together, as the infantry commander will often have to visit the headquarters of the artillery or 88-mm. dual-purpose guns. Forward artillery observation posts should also be placed close to the company commander of the infantry in whose sector they are operating. Reliance should not be placed on technical means of communication which usually break down at the critical moment.

“When time permits, the construction of dummy positions is of great importance.

“Early camouflage of all works is essential. On air photographs of the positions at Tobruk all the defense areas are clearly distinguishable. Mounds of earth thrown up must be planed off so as to cast no shadows. They must not stand out from the surrounding ground when looked at either from the ground or from the air. The camouflaging of communication trenches is particularly important.

“It is a mistake to attempt to link individual defense areas together by means of long communication trenches. Air photographs show this to have been tried in some places. These communication trenches weaken the power of resistance of the areas, since the personnel of the unit is insufficient to defend them, and they afford the enemy an opportunity of penetrating into the trench system under cover of darkness or a sandstorm.

“Mining is particularly important in the case of the small unit defense areas, which are usually broad. The following areas may have to be mined:

“Small gaps within defense areas;

“Large gaps between defense areas.

“Every care must be taken to mark mine fields clearly in order to prevent their becoming a hindrance and even a danger to our own operations.

“The safest way of marking mine fields is to lay them inside wire obstacles. Since this type of obstacle can be clearly recognized by the enemy, the field must be covered by fire to protect it against mine-lifting operations.

“Mine fields can also be marked by plowing a furrow

or by laying trip wires. These last two methods make it difficult for the enemy to recognize the mine fields, but they do not exclude the danger that our own troops (patrols, etc.) may come upon the mine field unawares, especially at night.

“The method of marking a mine field must therefore differ according to the tactical conditions. At times the method will be laid down by Division.

“It is particularly important to mark clearly gaps left for an advance of our armored forces. The 200th Engineer Battalion and the 5th Tank Regiment are asked to put forward suggested methods to Division.

“I ask all commanders and junior commanders to familiarize themselves and the troops under their command with these principles during this period of calm, so that they may become common knowledge and common practice.”

(Signed) VON RAVENSTEIN.

Section VIII. GERMAN MINES

1. TELLER MINES¹

a. Description

(1) The German Teller mine is constructed as follows (fig. 1):

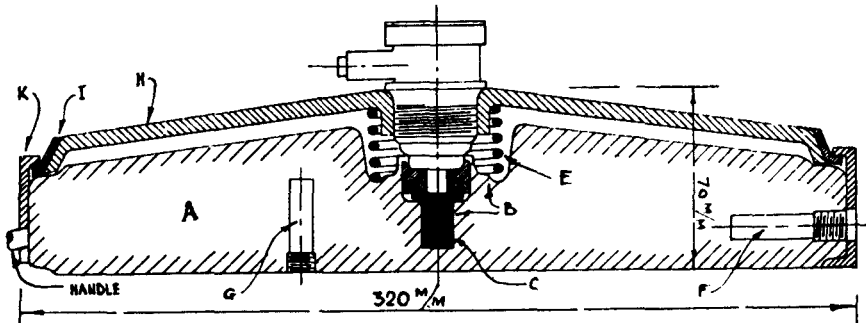

FIGURE 1. Sketch of German Teller Mine.

- (a) A cylindrical box, *A*, filled with tolite;
- (b) A detonator, *C*, the upper part of which is red;
- (c) Leather and metal washers;
- (d) A spring, *E*, on which the cover, *H*, rests;

¹ A flat percussion mine, usually round, about 12 inches in diameter and about 4 inches in thickness. Frequently a pressure bar is placed between a pair of mines (fig. 3). These mines will explode with deadly effect, over a limited area, when a person steps—or any other object moves—upon them. In addition to the safety precautions mentioned in the quoted document, the mine should also be examined to see whether any additional igniters have been inserted.

- (e) Two additional holes, *F* and *G*, which are threaded to take supplementary igniters;
- (f) A metallic belt, *K*, which holds the cover to the body.
- (2) The igniter (fig. 2) is composed of:

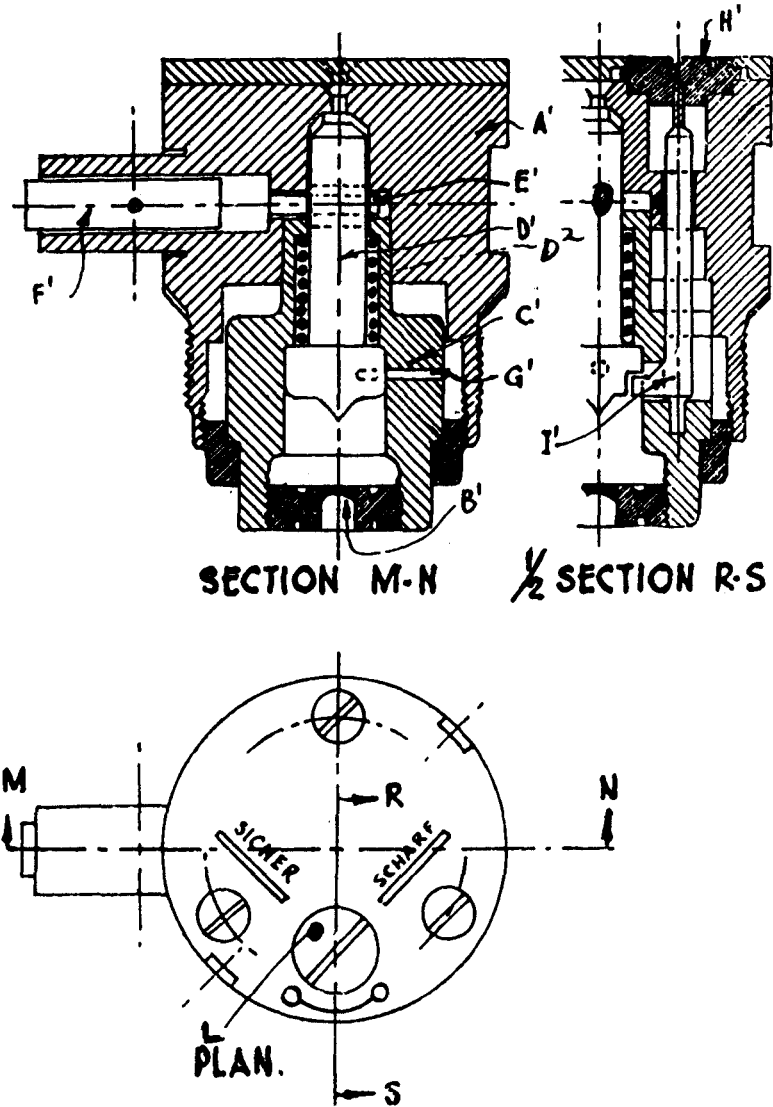

FIGURE 2. Cross Section of Teller Mine Igniter.

- (a) The body, A' ;
- (b) The cap, B' , which barely touches the top of the detonator;
- (c) A sliding body, C' , and a striker, D' , with a spring, $D2$. The sliding body and striker are held together by a shearing pin, G' ;
- (d) A safety or locking pin, F' , which slides into the hole, E' ;
- (e) Another safety device consisting of a bulge, I' , which is controlled by turning the screw head, H' .

The igniter operates when any pressure is put on it, as follows: the igniter presses on the washers in the hole, B , and the assembly, C' , is pushed up. When sufficient pressure is exerted, the shearing pin, G' , breaks, and the spring, $D2$, forces the striker down onto the detonator, thereby exploding the mine.

b. Neutralization

A German document captured in the Middle East, gives instructions for the neutralization of Teller mines. These instructions include turning the screwhead on the igniter to *Sicher* (safe) as well as pushing the safety pin F' home. Several Teller mines are now being examined by U. S. Engineers, however, and in a preliminary report they recommend that no attempt be made to turn the screwhead in either direction.

The igniter can, however, be locked by pushing home the safety pin, F' , which will prevent the striker, D' from falling.

If the regular locking pin has been removed, an ordinary

nail may be used as a substitute and inserted in the hole *E'*.

It should be remembered, however, that any mine may be made into a booby trap and in such a case normal methods of neutralization may serve only to detonate the mine.

The additional igniters which may have been inserted in the holes *F* and *G* may be neutralized in the same manner as the main igniter.

The mine should be carefully inspected, however, before attempting to neutralize any of the igniters, to see whether one or more of them is worked by a trip cord.

After the pin has been inserted in the hole, the whole igniter may be unscrewed and removed. This should be done only at some distance from the mine field so that in case of accidental explosion, the other mines will not detonate sympathetically.

Previous reports from the Middle East have stated that in a number of cases it has been found impossible to reinsert the safety pin. In this connection it has been suggested that the purpose of the molded rubber ring which lies between the main detonator-locking washer and the central sliding body in the igniter is to raise the latter slightly on removal of the safety pin so that the pin cannot be reinserted. However, tests on specimens which have recently arrived in Great Britain do not show any difficulty in replacing the pin. It appears, moreover, from the construction of the igniter, that when the safety pin is in position, the top of the striker is in contact with the small grub screw in the center of the igniter head, and cannot be further raised on withdrawal

of the safety pin. The difficulty in replacing the safety pin, therefore, is probably due to distribution of the igniter head or to partial shearing of the pin, *G'*.

c. Use of Pressure Bar (fig. 3)

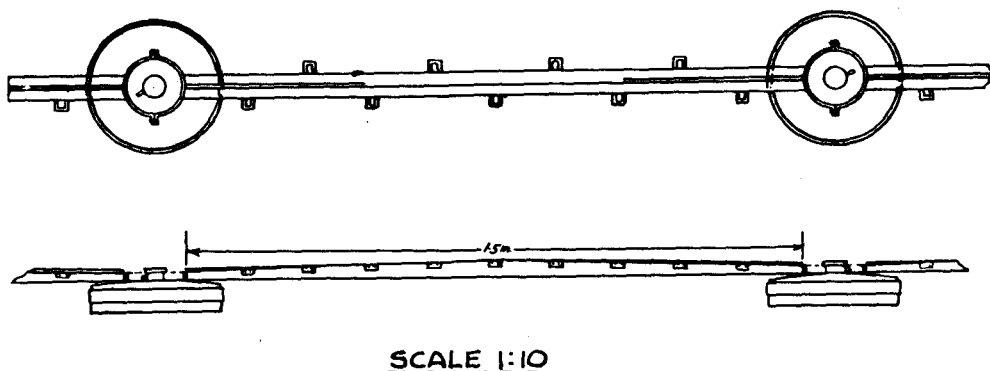

SCALE 1:10

FIGURE 3. Provisional Sketch of Pressure Bar As Used with Teller Mines.

The above-mentioned German document describes this device as follows:

(1) "For hasty construction of road barriers, a pressure bar, 1.5 m. (4.92 feet) in length, resting on two Teller mines, is employed. The bar is fixed to the mines by two half-collars which are screwed together.

(2) "The barrier is to be anchored with ropes or chains to objects on either side of the road.

(3) "These barriers are most useful when a detour is not possible; for example, in roads running beside a river or canal, or in a cutting.

(4) "The number of mines recommended is two to six according to the length of the barrier desired, there being a pressure bar between each pair of mines."

(5) *Comment.*—(a) A provisional drawing of the pressure bar, based on the above description and on a photo-

graph received from the Russian front, is given in figure 3. Dimensions, apart from the length, have been estimated from the photograph and are only approximate.

(b) The bar's "theoretical beam section," for maximum rigidity, implies a complicated method of construction, and the whole device seems an unnecessary addition to engineer stores.

(c) The purpose of the staples along the sides of the pressure bar is not clear. They may be intended for spiking the bar in position.

d. Laying of Mines

The following instructions for laying Teller mines (fig. 4)

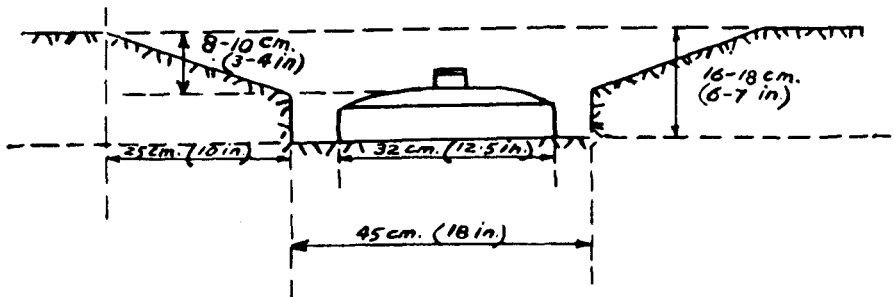

FIGURE 4. Method of Laying Teller Mines.

are given in a translation of a German document just received:

- (1) "Observe the correct depth and form of the trench.
- (2) "The covering layer should not be of greater thickness than 20 to 40 mm. ($\frac{3}{4}$ to $1\frac{1}{2}$ inches).
- (3) "Mines should not be laid in holes, as there is a definite chance that they may not detonate."³

³ The translation from the German under d. (3) is not clear, since the mines are laid in holes of shallow depth for the purpose of concealment. It is thought that this sentence might mean that "the mines should not be laid in deep holes," etc.

(4) "An obvious mound over the site of a mine should be avoided.

(5) "When laid in roads, the surface should be repaired where possible with tar or cement.

(6) "It is important to lay Teller mines from 80 to 100 mm. (3 to 4 inches) below the surface; that is to say, the lid must not be less than 90 mm. (3½ inches) below the surface; otherwise sympathetic detonation may occur when one mine is exploded. Mines should not be lower than 100 mm. (4 inches) below the surface; otherwise they may not function properly."

(7) *Comment.*—The figures given for depth of protective covering agree with a recent report received from Middle East, describing enemy mine fields at Tobruk. This report stated that the average depth of soil over the top of the igniter was 1 inch, and that the maximum depth was 2 inches. The figure of 100 mm. (4 inches) for maximum depth of a mine laid below the surface, taken in combination with an average of 30 mm. (1.2 inches) of loose covering above the igniter (height of igniter approximately 30 mm. (1.2 inches)), suggests that the site of the mine may be marked by a slight depression in the ground.

e. Use of Additional Igniters

No reports of additional igniters have been received, and officers of the British Middle East Force have always stated that Teller mines encountered are of normal type. It would be possible to use the normal igniter as a pull igniter by removing or shearing the shear wire and attaching a cord to the safety pin.

f. Sympathetic Detonation

Instances have been reported from Cyrenaica of Teller mines being spaced at 9-foot intervals. At this spacing, sympathetic detonation invariably occurs, and in one case the mines in a row 980 yards long went off simultaneously. Detonation at 15-foot intervals is uncertain, but British officers in the Middle East recommend special precautions when clearing mine fields at spacings closer than 20 feet.

g. Destruction

During the clearance of a Teller mine field at Tobruk it was found that the mines were over-sensitive, probably having been subjected to blast. It was therefore decided to destroy the mines in position. The field consisted of two rows at 15-foot spacing. One row was drawn towards the other by lengths of signal cable until the spacing was reduced to 7 feet 6 inches; and when one mine was fired, the whole field exploded.

h. Improvised Mines

German instructions for making improvised mines are as follows:

(1) "The improvised mines are to be made from prepared charges and standard igniters, and may be enclosed, partly or wholly, in wooden boxes.

(2) "High-explosive shells from which the fuze has been removed may be fitted with push igniters and used as antitank mines.

(3) "Hand grenades may also be used. Push igniters can be fitted to stick-grenade heads, either singly or in

clusters of seven tied together with wire. In the latter case the center head should carry the igniter.

(4) "Improvised mines should be laid by observing the same general principles as for Teller mines. In booby traps (i. e., simple traps for the unwary to walk on) push igniters should generally be employed. Only in special cases will pull igniters be employed."

i. Layout of Mine Fields

German diagrams for the layout of antitank mine fields are given in figure 5.

The following instructions accompanied the diagrams:

(1) "Distance between the mines from center to center shall be 4 m. (5 paces) when laid on the ground, and 8 m. (10 paces) when laid on the surface.

(2) "The density of the mine field is 24 mines per rectangle of 32 by 12 m. (40 by 15 paces). One rectangle is laid by a squad of 12 men, and each squad is responsible for laying 3 rectangles.

(3) "A company consists of three squads, and lays nine rectangles. In laying mines in open spacing, there shall be four rectangles per mine field, and a distance of 40 paces between mine fields, measured as shown in the diagram. This distance applies also to mines laid in close spacing.

(4) "Mine fields are mapped on a scale of 1/2,500, and the complete scheme transferred to a 1/10,000 map. Mine fields are to be marked by poles, sticks, branches, or wire."

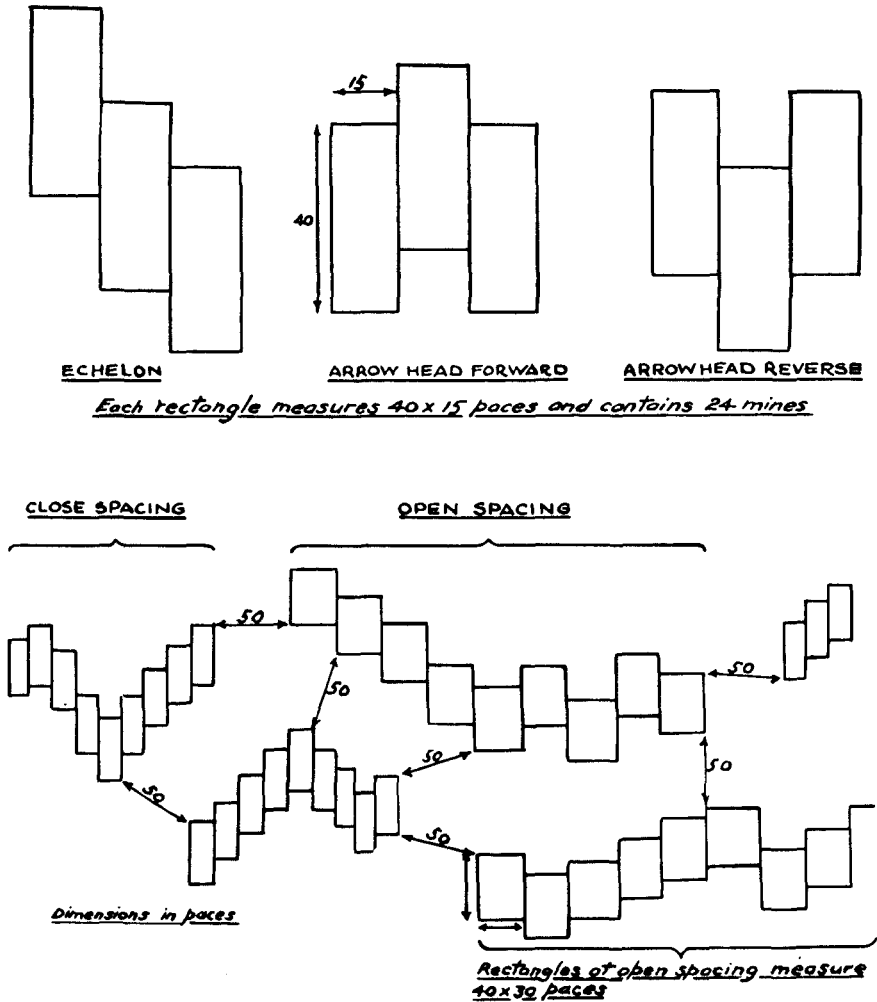

FIGURE 5. Layout of German Mine Fields

j. Antitank Mines

(1) In German and United Nations' experience with mobile desert warfare, it has been found essential for engineering and workshop units to carry a number of mines for emergencies.

(2) One report stated "200 mines at call are worth more than 1,000 available at 12 hours' notice."

k. Made-up Firing Devices

The German series of explosive blocks, detonators, igniters, and booby traps are screwed to match, whereas the British types of explosives and initiators are designed for sleeve fitting because of the greater variety of explosives in use.

2. MINE DEFENSES AT AGEDABIA

The following description of German defenses encountered at Agedabia⁴ has been received from the Middle East:

a. General Defense

The position was designed for all-around defense, with a perimeter at 3 to 5 miles from the center of the village. Wiring was scanty. On Italian sectors it consisted of a cattle fence, with three strands of wire on wooden pickets, whereas German sectors consisted of a box fence. Mines were laid about 20 yards inside the perimeter wire. At the date of the report, the depth and extent of these mine fields had not been determined.

b. Fire positions

Fire positions consisted of simple rifle pits, with gun pits at varying distances. These defenses bore every sign of improvisation, and were evidently incomplete. They appeared to have been only partially occupied. No overhead cover was observed. All tracks radiating from Agedabia were mined as shown in figure 6.

⁴ Also spelled *Jedabia* and *Jedaboya*.

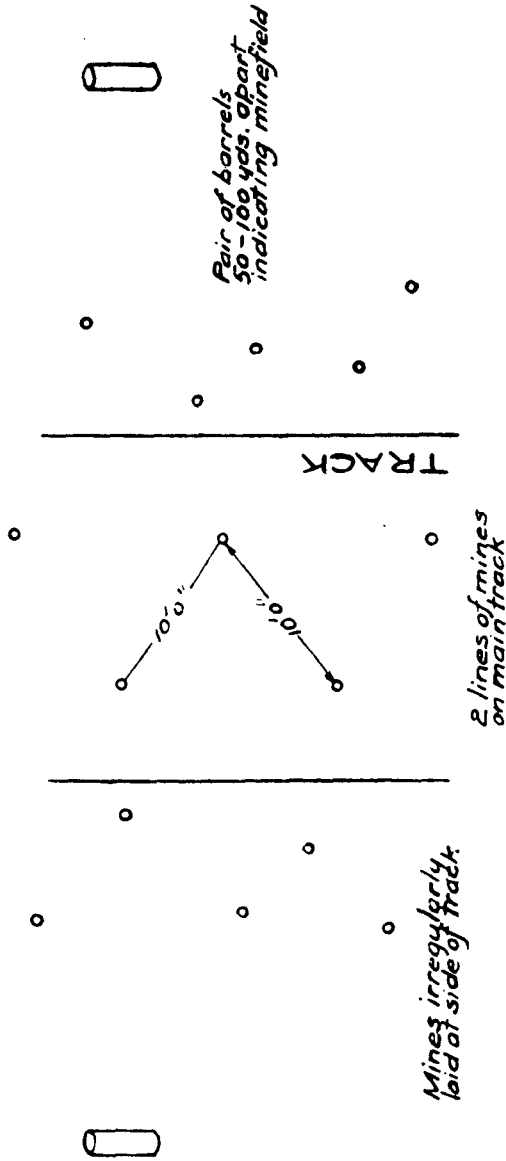

FIGURE 6. Layout of mines at Agedabia.

c. Mines

Teller mines were used exclusively on the tracks, holes having apparently been made with earth augers. In some cases two mines were placed one above the other 1 to 2 feet apart, the two being connected by a pull igniter. In Agedabia itself, open spaces and courtyards were freely mined, without any regular pattern, the mines being in some cases covered with cement.

(1) *Traps*.—Booby traps were set in many of the houses. These mostly consisted of a Teller mine, connected with a pull igniter either directly to a door or to a trip wire across the door. In some cases, hand grenades were fixed inside the door, in such a position that the man who set the trap must have gone out through a window.

(2) *Wells*.—No wells or cisterns were destroyed, but the principal ones were prepared with charges to be fired by booby traps. The main cistern contained a 40-pound charge and a Teller mine, connected with a pull igniter and cord to the manhole cover.

(3) *Road*.—The main road south of Agedabia had been heavily mined, mines being laid in real and artificial pot holes. In some cases a number of holes had been made, only a few of which contained mines. In sections where mines had been laid in the roadway, some were always laid indiscriminately in the shoulder of the road. A proportion of these mines contained bottom or side igniters. It was observed that the road was mined at each kilometer stone for the first 10 km. (6.25 miles) south of Agedabia. At approximately 24 km. (15 miles) south of Agedabia, two ditches (width, 8 feet; depth, 4 to 5 feet) had been cut across the 25-foot road. Both the

ditches themselves, and the detour made by the enemy for his own use, were heavily mined with both antitank and armor-piercing mines of standard German pattern.

d. Comment

(1) The substitution of Teller mines for prepared demolition charges in the preparation of booby traps in buildings and cisterns is noteworthy, and affords a further instance of their increasing use with pull-igniters for anti-personnel effect.

(2) In general, the report illustrates the extreme variation in layout of German mine fields, in spite of standard patterns laid down in training pamphlets. In this case, the spacing of 10 feet shown in figure 6 is exceptionally close.